

Alliance Group Nelson plant



Alliance Nelson is a meat processing plant located in Nelson, New Zealand. The site primarily processes sheep and bobby calves. Diesel was being used to generate hot water for cleaning and sterilising. The use of diesel for heating up water was both expensive and emissions-intensive, with 48% of the site carbon emissions coming from the diesel boiler.

To reduce both energy costs and carbon emissions, Alliance invested in a high-temperature heat pump (HTHP) to preheat hot water makeup to the diesel boiler.

Existing system

Alliance Nelson was previously using a 1.2 MW diesel-fired boiler to provide hot water heating for the plant. The boiler provided indirect heating from the primary hot water loop to three independently controlled heat exchangers. Across its operations, the Alliance Nelson hot water temperature requirements for processes were:

- 82 °C for sterilising and mixing to 65 °C washdown hoses
- 82 °C for the bobby calf spray tunnel
- 43 °C for hygiene stations.

Waste heat from the refrigeration plant and slaughter board steriliser drain was already being recovered for pre-heating hot water. A significant proportion of hot water make-up volume was preheated by the heat recovery systems, reducing the heating load on the diesel boiler. However, diesel was still being used to heat water from 35 °C to around 90 °C.

Heat pump solution

A 1 MW output ammonia HTHP was installed in 2019. The heat pump has allowed Alliance Nelson to successfully shift heating load from the diesel boiler to the more efficient high temperature heat pump (HTHP), providing significant savings.

Starting with an energy audit, DETA identified that the opportunities for an HTHP installation outweighed the short- and long-term economics of a biomass option,

MEAT PROCESSING

HEAT PUMPS

Project summary

Location: Nelson, New Zealand
 Facility type: Meat processing
 Consultant: Deta Consulting
 Heat pump supplier: Mycom
 Installer: Active Refrigeration

Equipment replaced: 1.2 MW diesel-fired boiler
 Water temperature set point: 75 °C
 New equipment: 1 MW ammonia HTHP
 Coefficient of performance: 4.1 (average)
 Estimated annual diesel savings: 48%
 Estimated annual energy savings: 1018 MWh
 Estimated annual emission savings: 19% site CO₂-e
 Annual cost savings: NZ\$70,800
 Total project cost: NZ\$536,000
 Reduction in \$/kg of product benchmark: 5%

which was an option being considered by Alliance. DETA identified that the lower cost option of replacing the diesel boiler with an integrated HTHP arrangement would allow Alliance to meet sterilisation, pasteurisation and processing standards for its global customers and significantly reduce reliance on diesel.

Alliance Nelson uses ammonia refrigeration systems and the waste heat from these systems was already pre-heating the water before it entered the diesel boiler via a desuperheater and oil cooler heat recovery circuit. The key process changes required to enable introduction of a HTHP involved integrating it within the existing heat recovery systems of the refrigeration plant.

Water previously entering the heating process (in the boiler) at 16 °C is now pre-heated to 35 °C with waste energy from the refrigeration system before entering the HTHP where it is heated to a discharge temperature of 63 °C (average over 12 months of post-commissioning data).

With its extensive knowledge of ammonia systems and the associated safety systems required, Active Refrigeration was selected as the preferred contractor for the installation.

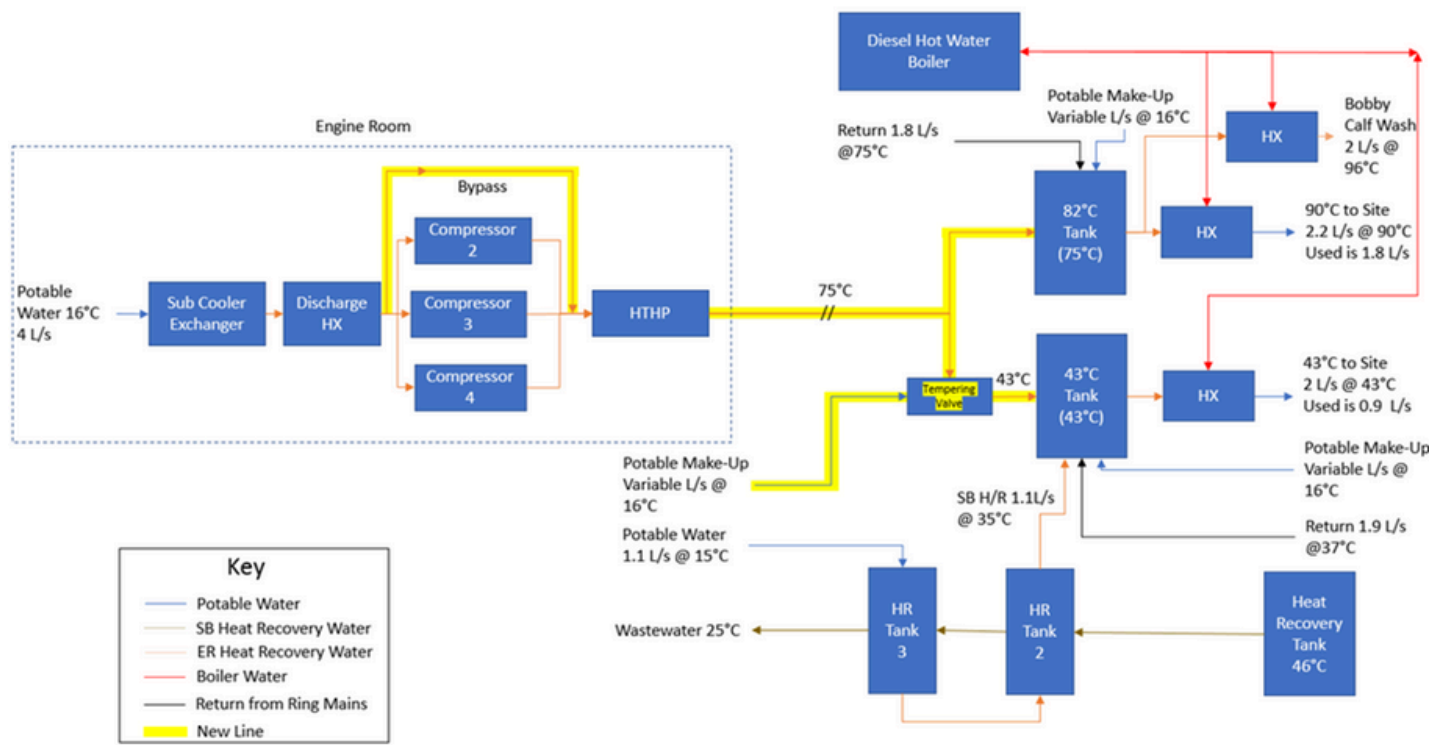

Diagram showing how the new HTHP integration was planned at the site.

Project costs

The project was estimated to cost approximately NZ\$536,000 for a 1 MW system to be supplied by Mycom and installed by Active Refrigeration, with an estimated internal rate of return of 51% and a net present value (five-year 10%) of NZ\$697,000.

Within NZ there are no white certificates available for project activities, however, the emissions trading scheme is linked to the carbon emissions associated with the fuel type. Therefore, by gained efficiency via utilisation of the heat pump and by switching to electricity, Alliance was able to reduce the costs associated with carbon, which facilitated favourable project economics.

Project outcomes

From the time of the energy audit to the recommendation of the HTHP installation, DETA worked with Alliance to prepare the business case, facilitate installation and then, most importantly, conducted monitoring and verification post-installation to record annual savings of 1,018 MWh in energy, NZ\$70,800 in energy cost savings and 1,308 MWh in diesel savings, with only a 290 MWh increase in electricity consumption. The project also saw a 5% reduction in the \$/kg product cost benchmark, improving affordability.

Other project benefits

- Improved social licence to operate
- Improved marketability of products
- Reduced carbon emission
- Reduced cost of operation
- Increased functionality/hot water production led to higher operational throughput and revenue.

Project observations, findings and challenges

As with any brownfield project, Alliance Nelson did encounter some implementation challenges. Control logic within the PLC caused the heat pump to trip off unexpectedly on several occasions, often due to oil levels, which required manual restarts. Alliance Nelson worked through these issues with the local electrical contractor and the system is now performing well.

The diesel boiler is now oversized for the boost heating duty since most of the temperature lift is provided by the engine room heat recovery and heat pump. The boiler now switches on and off far more frequently, rather than running on low fire for most of the time. The number of starts per week has increased from around 300/week to 600-840/week. This will be addressed by adjusting the diesel boiler burner to better suit the new heating duty.

Although the heat pump has delivered considerable energy cost savings for Alliance Nelson, ongoing commissioning to continue optimising the controls for the heat pump and hot water system could help to increase the run hours for the heat pump and offset more diesel. Ongoing monitoring and verification are important for an integrated project like this, to ensure that whole hot water system is operating as efficiently as possible.

“We recognise we have to play our part and improve our environmental footprint. Our customers and consumers have high expectations for how the co-operative manages the natural environment and they also expect transparency and ethical food production. It is fantastic that the high temperature heat pump makes sound environmental sense and good business sense too.”
Alliance Group Chief Executive, David Surveyor